

## CTA88 remote control chip Application boards

**The CTA88 chip is a simple encoder/decoder for use with ISM band telemetry modules. It permits a simple, one way wireless link to be established, for simple remote control applications, with a minimum of effort and no customer software input.**

**These TX and RX application boards are designed to allow easy evaluation of the CTA88 device in elementary jobs. They provide a simple 8 channel implementations of remote control, using either LMT/LMR or BiM footprint wireless radio modules.**

### Features

- 8 bit address and 8 bit data select switches
- 8 relays to control mains powered devices rated up to 8A, 250VAC/30VDC
- Visual indication of valid code received and active relays
- RF module range testing
- 8 Push buttons for momentary control of relays
- Momentary, Latched outputs
- Dynamic relay state changes
- Setup is simple as Plug-and-Play
- RF Remote Control Demonstration



Figure 1: CTA88 RX application board



Figure 2: CTA88 TX application board

### Kit Contents

The CTA88 application kit is supplied with the following contents:

- 2 CTA88-000-DIL
- 1 CTA88 Encoder board (ENC)
- 1 CTA88 Decoder board (DEC)
- 1 Radiometrix Transmitter module (*ordered separately*)
- 1 Radiometrix Receiver module (*ordered separately*)
- 1/4-wavelength monopole or helical antennas
- 4 Jumpers
- 1 CTA88 data sheet
- 1 CTA88 Application board manual
- 1 Data sheet of Radio module ordered

### Additional requirement

- External power supply or 12V DC power adaptor

## Common features:

<b>Interfaces</b>	
Input/output	8 x 3.81mm pitch 3 pin "Phoenix" two part connectors (JP1 – JP8)
Power	2.1mm DC power connector (JP15) and 2 pin "Phoenix" (JP14). (these inputs are diode "or'ed" together) On/off slide switch (S3) on pcb
CTA88 mode	3 position jumpers (JP12)
CTA88 address	8 position DIP switch (S1)
Radio channel	4 position DIP switch (optional) (S2)
Radio setup	2 pin 0.1" pitch "Molex" serial connection (optional) (JP13)
RF	SMA (or optional screw terminal) (CON1)
<b>Indicators</b>	
	Power on LED (D10)
	send/receive LED (D9)
	8 x I/O pin state LEDs (D1 – D8)
<b>CTA88</b>	
	Clock 3.58MHz (ceramic resonator)
	Data rate 1kbit/sec Biphase coded burst
	Part: Leaded 28 pin, in socket
<b>Size</b>	
TX & RX boards	115 x 86 x 20mm (excluding connectors) (four 3.3mm diameter mounting holes are provided)
<b>Operating temp.</b>	
	-20 to +70 degrees centigrade (some radios may be limited to -10/+55)
	(Storage -30 to +70 degrees)

## CT88 TX Application board

<b>Inputs</b>	2.5 to 50v (5mA) opto isolated inputs with manual "test" pushbuttons (SW1 – SW8)
	LED indicators on all channels
	Link selectable DC supply (5v aux, 5v main, or unregulated Vin) on each channel. (fit one link only on jumper JP10)
	Link selecting low power / normal mode (JP11)
<b>Supply</b>	6 –15V
<i>idle current:</i>	4mA (standard mode) 3uA (low power mode)
<i>transmit current</i>	(depends upon radio module fitted) 50mA with LMT2-433-5 fitted
<b>Radio modules</b>	any LMT version
	transmitter versions of NiM2, BiM1, BiM1H, BiM2A, BiM3A/B RDL2 (tx). (Fit R32. Idle current increases by 10mA)

## TX application board jumpers and DIP switches

The TX encoder board has 4 jumpers and 2 DIP switches. The jumpers are used to select the number of operating modes featured in the board while the 4 way and 8 way DIP switches are used for frequency channels selection and address selection respectively.

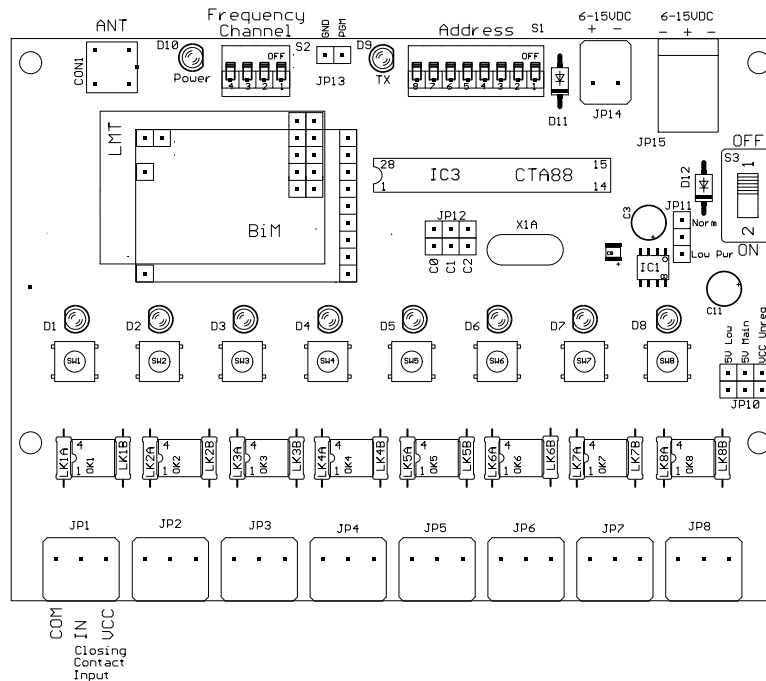

**Figure 3: CTA88 TX demo board PCB (top view)**

Assumed the board is held "long side horizontal" with the RF and power connectors at the top

Jumper.	Name	Function	Position	Mode
JP10	SUPPLY	Selects which power supply is fed to the user inputs busbar (Only EVER fit one jumper on this header)	<b>Left</b>  <b>Middle</b>  <b>Right</b>	Low current / always present +5v (100mA max, total) (default)  Main +5v (250mA). In low power mode this rail is only Present during actuation  Unregulated Vin, via switch and 1A schottky diode
JP11	LOW POWER	Selects low power or normal mode Normal mode draws 5mA quiescent current: Low power draws 3uA, but if "low power" operation is selected then the coder device and transmitter are only activated when one of the inputs is "active". Therefore only modes 001 and 100 can be used with this option.	<b>Up</b>  <b>Down</b>	Normal  Low power (default)
JP12	MODE	Selects Operating modes	see operating mode section below	
JP13	RADIO SETUP	Radio setup (only for LM series radios)	Ground (GND) and the RS232 input to the PGM pin	
R32		Factory fitted for RDL2 (tx) use. Idle current increases by 10mA		



## RX application board DIP switches

The RX application board features a 4 way (S2) and an 8 way (S1) DIP switches. The optional 4 way DIP switch which is used for parallel frequency channel select is only required when our multi channel LM series radios like LMR1 / LMR2 s are used. The 8 way Dip switch is used to set an 8 bit (256) unit address.

## Operating modes

Device operation is set up by a 3 bit word, on the C0-C2 jumpers. This is JP12 on both the TX and the RX boards.

C2 C1 C0	Encoder Transmitter Modes ( 1 = 5V Jumper Link Inserted )
0 0 0	Device is inactive
0 0 1	Send single burst, once only (on reset, and on each C0 low/high transition)
0 1 0	Send continuously
0 1 1	Send single burst on any change of Data input word
1 0 0	Send continuously while any Data input pin is high
1 0 1	Send a burst on average every 1.75 seconds. A P/N sequence generates a delay of 1 -2.5s between bursts
1 1 0	Serial mode (see notes)
1 1 1	Transmitter test. Send a constant 250Hz squarewave (C0=H, C1=H, C2=H)

C2 C1 C0	Decoder Receiver Modes ( 0 = 0V Jumper Link Removed )
0 0 0	Local test. Data output word equals Address input word
0 0 1	Output last data received (150mS timeout)
0 1 0	Output last data (3 second timeout: see notes)
0 1 1	Hold last data received
1 0 0	D0-3 'set' corresponding bit, D4 resets D0, D5 resets D1 .. and so on
1 0 1	A '1' on any bit toggles the state of the corresponding output pin
1 1 0	Serial (see notes)
1 1 1	Link test. Data word outputs most recently received burst address

## Which modes to use?

The CTA88 have a variety of operating modes. These are better understood by relating them to different applications:

1. **Wire replacment:**. Operate transmitter in mode 010 (continuous: allows the STB output to be used as a 'good link' indicator) and receiver in mode 001.

If receiver operates in latched (011) mode then 'chattering' of the output is reduced (at extreme range, or with interferers present), but the link is no longer fail safe  
Latched mode is also compatible with send on change (011)

2. **Momentary push buttons:** Transmitter in mode 100 (send while any input is high), receiver in 001. Outputs remain high for as long as the button is held down. This is the mode one would choose to control (for instance) a pan/tilt head (D0= slew left, D1 = slew right, etc)

3. **Controlling four lights:** Use transmit mode 100 (send while high) or 011 (send on change), with the receiver in mode 100. This gives four outputs (D0-D3), each set by one transmitter input (D0-D3) and reset by another (D4-D7)

4. **Monitoring infrequent events** (such as door open/shut): Use transmitter in periodic transmit (101, to keep channel occupancy and power usage low), and receiver on 010 (3 second timeout), 011 (hold last burst) or 110 (serial data output, to a PC or data logging device).

In this mode the transmit duty cycle is less than 10% on average, and the variable delay between bursts permits same channel operation of several CTA88 links with minimum transmit collisions

5. **Send burst on trigger event**: Set transmitter to mode 000 (off) and use C0 line high as a 'strobe' line. A pulse between 100uS and 25mS will initiate a single transmission.

This gives an idea of the usable combinations, but with a little imagination others will be found

**Incompatibilities:** Certain operating modes are not compatible with some of the others:

**RX 101 (toggle)** doesn't work with TX 101 (periodic send) as the outputs switch on and off at the send rate

**RX 100 (set and reset)** doesn't work with TX 101 (as the response is sluggish) and doesn't need TX 010 (constant)

RX 101 (toggle) is also not best suited to extreme range operation, where the initiation can be a little sporadic.

(At extreme range, latched (011) or set/reset (100) are the best receiver modes, combined with TX 100 (send on any '1') as in this mode the failure of any single burst to be received matters less, as the operator can continue to operate the transmitter until the receiver actuates )

**Serial operation:** The CTA88 is capable of a very simple, single byte, serial link operation. It is selected by a '110' mode input.

This function is mainly intended for diagnostic work in the lab, but it does allow a pc to send or receive CTA88 command bursts. Address is still selected by the parallel inputs

**On the RX:** D4 = 'true' RS232 output (+ve = low (0), 0V = idle/mark state)  
D5 = 'inverted' RS232 output (+ve = idle/mark' (1) state)  
D6 : high for 500uS before, and during, serial byte output

**On the TX** D4 = RS232 input  
D5 : low = set 'true' input polarity, high = set 'inverted' input polarity

In all cases a single 9600 baud byte is received or sent.

The link is not transparent: on the TX end the 'tx on' pin can be used as a 'busy' output

**Timeout:** In modes 001 and 010, the receiver outputs the last received data for a given period, before resetting D0-D7.

Any subsequent transmission will over-ride the current output state and reset the timer, even if the timeout period has not expired.

The short period is set to be slightly longer than the time between consecutive transmit bursts in a continuous mode.

The long timeout is usable with the randomised periodic transmission mode (101), as the 3 second timeout is longer than the longest delay between transmissions in this mode.

Versions of the chip can be supplied with this period extended to suit customer requirements.

## CTA88 application boards: customisation options

Features	Standard	Options
Radio module	n/a	LMR/LMT(any), NiM2, BiM (any), CVR1 (5v), RDL2,
RF connector	SMA	MCX, SMB, screw terminal
Interface connectors	3.81mm 2 part	single part screw terminals
Address select	DIP switch	side operating DIP, ERG type slider, jumpers
Channels	8	partial build is possible (1,2,4 ..etc channels)
LEDs	fitted	no leds
Push buttons	fitted	no pushbuttons
		only pushbuttons (no input circuits)
Voltage (rx)	12v	24v, and +5v only, versions are possible
(tx)	6 - 24v	n/a

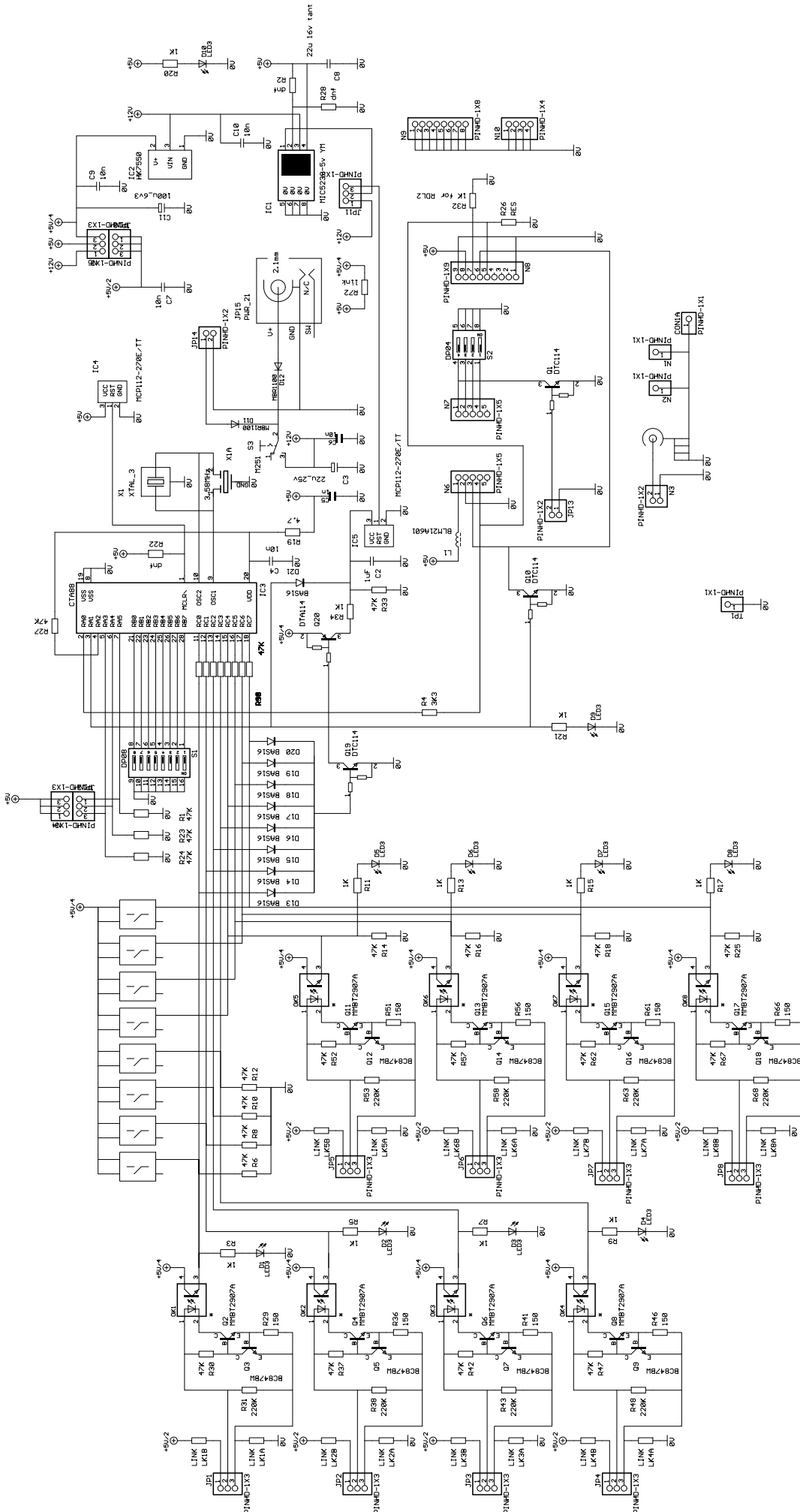

Figure 5: CTA88 TX application board Schematic

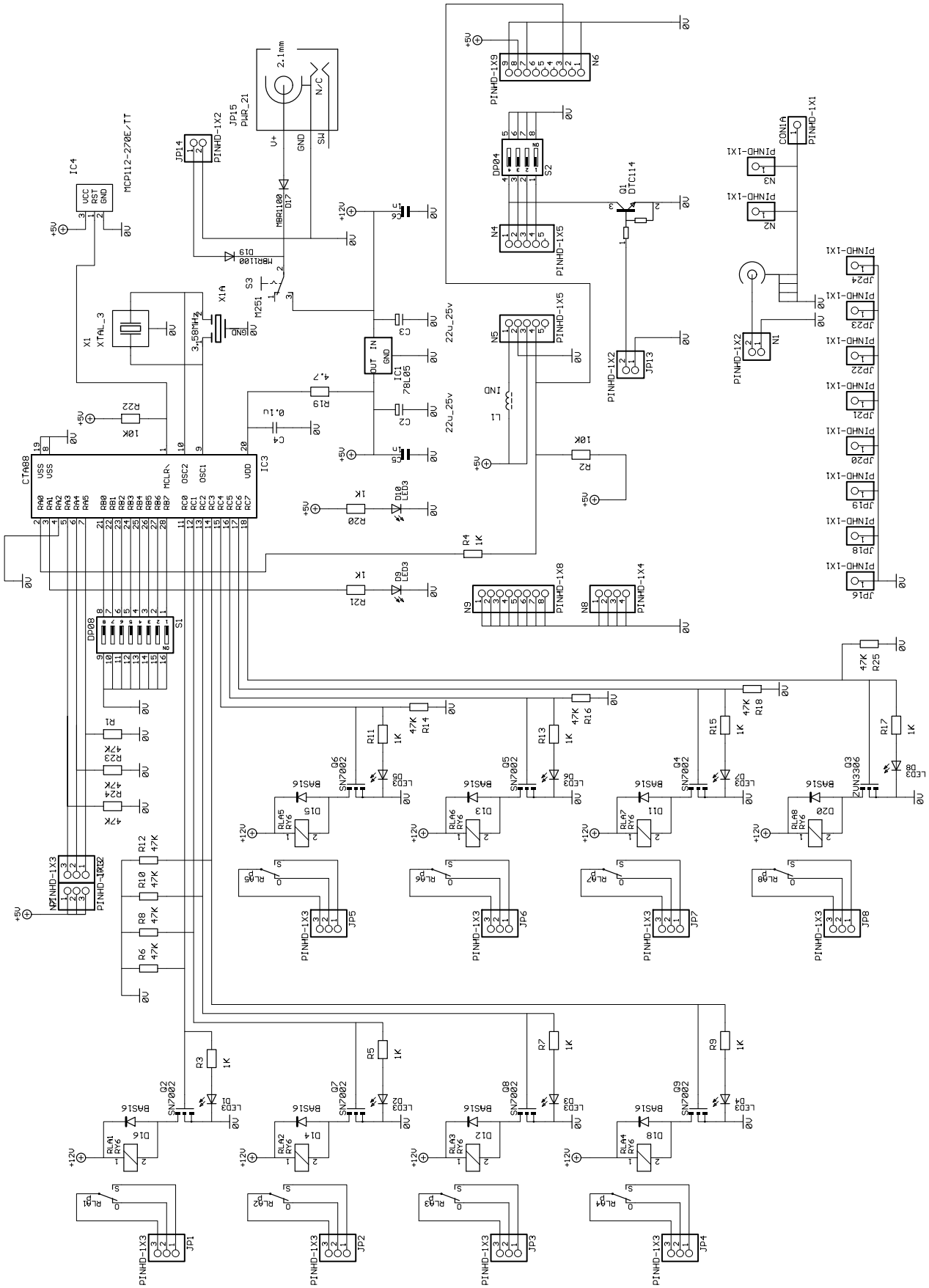

Figure 6: CTA88 RX application board Schematic

## Radiometrix Ltd

Hartcran House  
231 Kenton Lane  
Harrow, Middlesex  
HA3 8RP  
ENGLAND  
Tel: +44 (0) 20 8909 9595  
Fax: +44 (0) 20 8909 2233  
[sales@radiometrix.com](mailto:sales@radiometrix.com)  
[www.radiometrix.com](http://www.radiometrix.com)

### Copyright notice

*This product data sheet is the original work and copyrighted property of Radiometrix Ltd. Reproduction in whole or in part must give clear acknowledgement to the copyright owner.*

### Limitation of liability

*The information furnished by Radiometrix Ltd is believed to be accurate and reliable. Radiometrix Ltd reserves the right to make changes or improvements in the design, specification or manufacture of its subassembly products without notice. Radiometrix Ltd does not assume any liability arising from the application or use of any product or circuit described herein, nor for any infringements of patents or other rights of third parties which may result from the use of its products. This data sheet neither states nor implies warranty of any kind, including fitness for any particular application. These radio devices may be subject to radio interference and may not function as intended if interference is present. We do NOT recommend their use for life critical applications.*

*The Intrastat commodity code for all our modules is: 8542 6000*

### R&TTE Directive

*After 7 April 2001 the manufacturer can only place finished product on the market under the provisions of the R&TTE Directive. Equipment within the scope of the R&TTE Directive may demonstrate compliance to the essential requirements specified in Article 3 of the Directive, as appropriate to the particular equipment.*

*Further details are available on The Office of Communications (Ofcom) web site:*

***<http://www.ofcom.org.uk/>***

Information Requests  
Ofcom  
Riverside House  
2a Southwark Bridge Road  
London SE1 9HA  
Tel: +44 (0)300 123 3333 or 020 7981 3040  
Fax: +44 (0)20 7981 3333  
[information.requests@ofcom.org.uk](mailto:information.requests@ofcom.org.uk)

European Communications Office (ECO)  
Peblingehus  
Nansensgade 19  
DK 1366 Copenhagen  
Tel. +45 33896300  
Fax +45 33896330  
[ero@ero.dk](mailto:ero@ero.dk)  
[www.ero.dk](http://www.ero.dk)