

VHF Narrow Band FM Transmitter

The NTX1C is a frequency programmable transmitter in TX1 form factor. Using cutting edge integrated RF devices, it offers low power narrowband operation in Radiometrix SIL standard pin out and foot print. It is ideally suited to applications where existing wideband modules have insufficient range and where traditional narrowband multichannel modules would physically be too big to fit in.

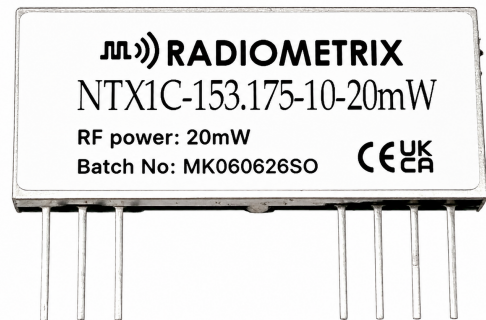

Figure 1: NTX1C-169.4125-5

Features

- Conforms to EN 300 220-2 and EN 301 489-3
- Fully integrated sigma-delta PLL synthesizer based design
- Vibration resistant (negligible microphony)
- Data rates up to 5 kbps for standard module
- Factory programmable custom frequency within 142-175MHz. No crystal lead-times
- Usable range over 500m (with suitable aerials and matching receiver)
- Fully screened. Very low profile
- Re-programmable via RS232 interface
- Low power requirements

Applications

- Keyfobs and other hand held terminals
- Small form factor data loggers
- Industrial telemetry and telecommand
- In-building environmental monitoring and control
- Covert, high-end security devices
- Unobtrusive fire alarm sensors
- Heavy vehicle/machinery controls

Technical Summary

- Operating frequency: 151.300MHz Australian LIPD
 154.570MHz US MURS
 169.4125MHz EU SRD
 173.225MHz UK Fixed Alarm
 173.250MHz UK Telemetry and Telecommand
- Transmit power: +10dBm (10mW), +13dBm (20mW) option available
- Supply range: 3.1 – 15V (will operate down to 2.9V)
- Current consumption: 24mA @ 10mW
- Data bit rate: 5kbps max.
- ±5ppm stability VCTCXO reference
- Serial configuration by inverted RS232 at 3V CMOS level
- Size: 32 x 13 x 6 mm

Evaluation platforms: NBEK + matching carrier board

NTX1C

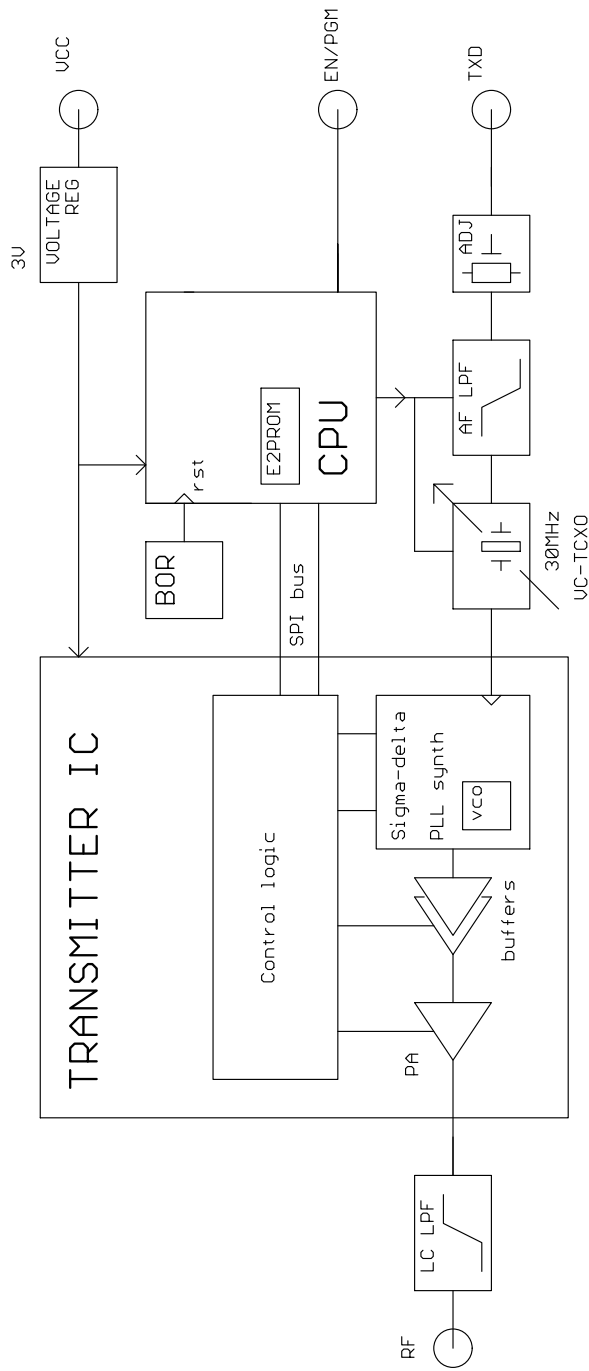
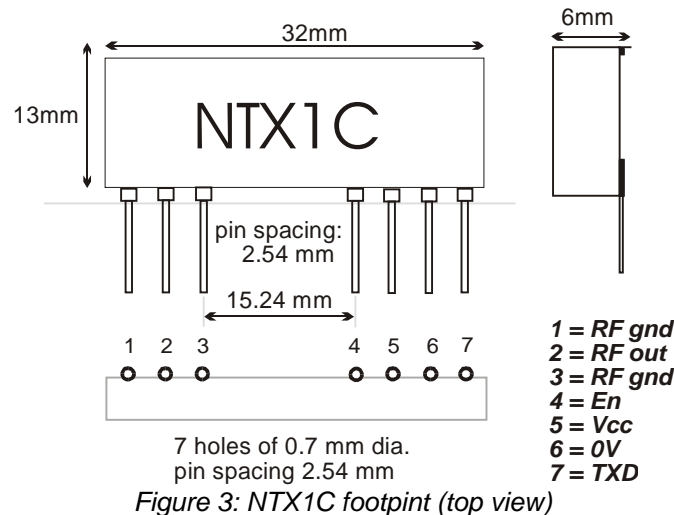

Figure 2: NTX1C block diagram

Functional description

The NTX1C transmitter consists of a highly integrated sigma delta (fractional N) synthesizer based single chip RF device, configured over an SPI serial bus by an on-board microcontroller. The primary frequency reference for the transmitter is a 10MHz VCTCXO. Modulation is applied directly to this reference via an AF baseband filter (rather than using the chip's internal modulator) to permit a wider range of baseband data rates and waveforms. Operation is controlled by the EN (Enable) line, the transmitter achieving full RF output typically within 5ms of this line being pulled high. The RF output is filtered to ensure compliance with the appropriate radio regulations and fed to the 50Ω antenna pin.



Pin description – NTX1C

NTX1C pin	Name	Function
1, 3	RF GND	RF ground is internally connected to the module screen and pin 6 (0V). These pins should be directly connected to the RF return path - e.g. coax braid, main PCB ground plane etc.
2	RF out	50Ω RF output to the antenna
4	EN/PGM	Pull high to enable Transmitter (3V CMOS logic) 9600 baud 0V-3V Inverted RS232 (UART) Programming command input
5	VCC	2.9V – 15V DC power supply
6	0V	Ground
7	TXD	DC coupled input for 3V CMOS logic. $R_{in} = 100k\Omega$

Notes:

- Pinout and footprint is as TX1
- Serial programming is by the application of a 3V logic level inverted RS232 datastream at 9600 baud to the EN/PGM pin. The unit must be fully enabled (5ms after the rising edge of the EN signal) before a programming burst can be properly decoded.
- EN has a 100kΩ pulldown resistor to ground.
- In the 'off' state there are no transmit state spuri
- The unit will operate (with marginally reduced specifications and lower (6-8mW) output power) from a 2.9 – 3.0V rail. This must be well regulated and without noise or ripple, as in this state the unit's internal regulator no longer operates, and provides no supply rejection.
- Switching time as controlled by the EN pin is <5ms, but when power is first applied to the unit there is a 20ms long "calibration" period before the transmitter becomes active

Condensed specifications

Frequency	151.300MHz Australian LIPD 154.570MHz US MURS 169.4125MHz EU SRD 173.225MHz UK Fixed Alarm 173.250MHz UK Telemetry and Telecommand Any other custom frequency within 142-175MHz Low (142-149MHz) Mid (150-159MHz) High (160-175MHz)
<i>Frequency stability</i>	±1.5kHz
<i>Channel spacing</i>	25kHz standard 12.5kHz or 20kHz variants
Operating temperature	-20 °C to +70 °C (Storage -30 °C to +70 °C)
Spurious radiations	Compliant with ETSI EN 300 220-2 and EN 301 489-3
Transmitter	
Output power	+10dBm (10mW) ±1dB
Peak deviation	±3kHz for 25kHz channel spacing ±1.5kHz for 12.5kHz channel spacing
TX on switching time	5ms from EN transition
Modulation type	FM (F3D)
TX modulation bandwidth	DC – 3kHz (3V CMOS compatible)
Adjacent channel TX power	<-37dBm
TX spurious	<-40dBm (no RF output in Standby)
Supply	
Voltage	3.1V – 15V (usable down to 2.9v)
Current	24mA @ 10mW (nominal) <3µA standby (EN low or floating)
Inputs	data (CMOS/TTL compatible)
Size	32 x 13 x 6 mm
Recommended PCB hole size	0.7mm after plating.

Channel Programming

At the heart of the device is a fractional N synthesizer locked to a high stability VCXO. The minimum step size of this PLL is 12.397Hz.

The data required by the PLL consists of two coefficients: the integer (INTE) and the fraction (FRAC). Output frequency relates to these values thus:

$$Freq = \left(INTE + \frac{FRAC}{2^{19}} \right) \times \frac{2 \times VCTCXO}{Outdiv} \quad \text{where } \frac{2 \times 30MHz}{24} = 2.5MHz$$

NTX1C uses 10MHz VCTCXO multiplied by 3 to give a 30MHz reference frequency, and Output Divider (Outdiv) value for 142MHz-175MHz band is 24.

For correct operation, the component (FRAC / 2¹⁹) must have a value between 1 and 2

$$Freq = \left(INTE + \frac{FRAC}{2^{19}} \right) \times 2.5MHz \quad 1 \leq \frac{FRAC}{2^{19}} \leq 2 \quad 524,288 \leq FRAC \leq 1,048,576$$

$$INTE = WholeNum \left[\frac{Freq}{2.5} \right] - 1 \quad FRAC = \left(DecimalNum \left[\frac{Freq}{2.5} \right] + 1 \right) \times 524288$$

In interface terms, these coefficients are expressed as a 32-bit binary word (eight hexadecimal digits) where the most significant byte comprises the integer value, and the remaining three bytes (24 bits) make up "fraction"

NTX1C Example: $\frac{154.570MHz}{2.5MHz} = 61.828$

$$\frac{169.4125MHz}{2.5MHz} = 67.765$$

INTE = 61-1 = 60 (0x3C)

FRAC = (0.828 +1) × 524288 = 958398 (0x0E9FBE)

FRAC2 = 0x0E

FRAC1 = 0x9F

FRAC0 = 0xBE

INTE = 66 (0x42)

FRAC = (0.765 +1) × 524288=925368 (0x0E1EB8)

FRAC2 = 0x0E

FRAC1 = 0x9F

FRAC0 = 0xBE

$$Freq = \left(60 + \frac{958398}{524288} \right) \times 2.5 = 154.5699978MHz = 154.570MHz - 2.2Hz$$

$$Freq = \left(66 + \frac{925368}{524288} \right) \times 2.5 = 169.4124985MHz = 169.4125MHz - 1.5Hz$$

When programming the NTX1C, keep in mind that the unit maintains in SRAM the current values of all programmable values (frequency, band of operation, RF power and frequency offset adjustments values) and that toggling the NTX1C EN/PGM pin does NOT erase or corrupt them. These values are only loaded from EEPROM at cold start power-up (but not when the NTX1C EN/PGM pin is cycled)

There is one "write all values to EEPROM" command. It is usually necessary to load the relevant current operating RAM value(s) and THEN issue a suitable command to write the RAM value to EEPROM.

The NTX1C EEPROM stores Frequency coefficients, RF Power level, Frequency Offset and the Band select constants. Programming a value or coefficient over the serial bus over-writes the previous value and implements this change on the PLL immediately, but does not change the EEPROM contents until a relevant "program EEPROM" command is issued

In general, the most recent stimulus received by the unit will decide the operating frequency.

Whenever a frequency coefficient is programmed into the unit, the frequency will change immediately to this new value regardless of other modes or operation. This is the simplest and most flexible means of controlling the unit.

Serial interface commands

NTX1C PGM serial interface consists of an 9600bps, 8 data bits, No Parity, 1 Stop bit, 0V-3V level Inverted RS232 (UART) data stream applied to the EN/PGM pin (the idle state of the interface will turn the transmitter on)

Every command string starts with the phrase "@PRG_" and terminated with Carriage Return <cr>.

The characters in a command string must not be separated by more than 5ms (so typing individual characters on a terminal keyboard will NOT work), but a pause of at least 10ms is required between commands (more following a BURN_ROM command. In this case a much longer idle period, of 50ms at least, is needed for EEPROM programming)

User commands

Commands	Function
@PRG_iif2f1f0<cr>	sets the transmitter frequency iif2f1f0 is an 8 digit hexadecimal number, coding 4 bytes: ii is the "integer" value f2 most significant FRAC2 byte in the 24 bit FRAC word f1 bits 8 through 15 of the fraction word (FRAC1) f0 least significant FRAC0 byte e.g. @PRG_420E9FBE<cr> to program 169.4125MHz
@PRG_BURN_ROM<cr>	write current setup into EEPROM
@PRG_POWER 00<cr> @PRG_POWER FF<cr>	Turn the unit completely OFF (power down) Turn the unit ON (power up) EN pin can also be cycled
@PRG_00000000<cr>	Re-sets itself to the values currently stored in EEPROM (this usually only happens at power-up)

Factory alignment commands

Commands	Function
@PRG_POWER pp <cr>	Sets the RF Power output pp is a 2 digit hexadecimal number (in the range 00 to 3F) 00 - power OFF, FF – power ON e.g. @PRG_POWER 32<cr>
@PRG_TRIM+ aa <cr>	set an "up" offset aa is 00 (0Hz) to 7F (+1574.4Hz) at 12.397Hz per bit @PRG_TRIM+1E<cr>
@PRG_TRIM- aa <cr>	sets a "down" offset aa is 00 (0Hz) to 7F (-1574.4Hz) at 12.397Hz per bit
@PRG_BAND# bb	band divider value (bb) 08 850-1050MHz 0A 425-520MHz 0B 280-350MHz 0D 140-175MHz e.g. PRG_BAND# 0D<cr>
@PRG_BURN_ROM<cr>	write current setup into EEPROM

Ordering Information

Standard frequency setup for 4 channel MTX radios uses these default channels:

Part no.	RF Power	Frequency	Channel Spacing	Application	Country
NTX1C-144.390-5	10	144.390	25	APRS	USA
NTX1C-144.800-5	10	144.800	25	APRS	EU
NTX1C-151.300-5	10	151.300	25	LIPD	Australia
NTX1C-151.820-5-12k5-20mW	20	151.820	12.5	MURS	USA
NTX1C-154.570-5	10	154.570	25	MURS	USA
NTX1C-154.600-5-20mW	20	154.600	25	MURS	USA
NTX1C-169.40625-5	10	169.40625	12.5	SRD, Meter Reading	EU
NTX1C-169.4125-5	10	169.4125	25	SRD, Meter Reading	EU
NTX1C-173.225-5	10	173.225	25	Fixed Alarm	UK
NTX1C-173.225-5	10	173.250	25	Telemetry and Telecommand	UK

Note: Also available on the other 12.5kHz / 20kHz / 25kHz channel spacing 142-175MHz VHF band frequencies with RF power output of 10mW / 20mW.

Matching Receiver.

NRX1B is the matching frequency programmable single frequency VHF receiver. However, any 12.5Hz / 20kHz / 25kHz channel spacing Narrow Band FM Receiver can also be used.

Radiometrix Ltd

**Hartcran House
231 Kenton Lane
Harrow, Middlesex
HA3 8RP
ENGLAND**

**Tel: +44 (0) 20 8909 9595
Fax: +44 (0) 20 8909 2233
sales@radiometrix.com
www.radiometrix.com**

Copyright notice

This product data sheet is the original work and copyrighted property of Radiometrix Ltd. Reproduction in whole or in part must give clear acknowledgement to the copyright owner.

Limitation of liability

The information furnished by Radiometrix Ltd is believed to be accurate and reliable. Radiometrix Ltd reserves the right to make changes or improvements in the design, specification or manufacture of its subassembly products without notice. Radiometrix Ltd does not assume any liability arising from the application or use of any product or circuit described herein, nor for any infringements of patents or other rights of third parties which may result from the use of its products. This data sheet neither states nor implies warranty of any kind, including fitness for any particular application. These radio devices may be subject to radio interference and may not function as intended if interference is present. We do NOT recommend their use for life critical applications.

The Intrastat commodity code for all our modules is: 8542 6000.

R&TTE Directive

After 7 April 2001 the manufacturer can only place finished product on the market under the provisions of the R&TTE Directive. Equipment within the scope of the R&TTE Directive may demonstrate compliance to the essential requirements specified in Article 3 of the Directive, as appropriate to the particular equipment.

Further details are available on The Office of Communications (Ofcom) web site:

<http://www.ofcom.org.uk/radiocomms/ifi/>

Information Requests

Ofcom

Riverside House

2a Southwark Bridge Road

London SE1 9HA

Tel: +44 (0)845 456 3000 or 020 7981 3040

Fax: +44 (0)20 7783 4033

information.requests@ofcom.org.uk

European Radiocommunications Office (ERO)

Peblingehus

Nansensgade 19

DK 1366 Copenhagen

Tel. +45 33896300

Fax +45 33896330

ero@ero.dk

www.ero.dk
