

UHF FM Data Transmitter and Receiver Modules

European versions: TX3C-869-xx/RX3B-869-xx
US version: RX3B-914-xx only
Data speed options (-xx) : -10 (10kbps), -64 (64kbps)

The TX3C & RX3B are miniature UHF radio transmitter & receiver modules designed for PCB mounting. They facilitate the simple implementation of data links at speeds up to 64kbps and distances up to 75m in-building or 300m over open ground.

TX3C Transmitter

RX3B Receiver

Features:

- Frequencies available as standard: 869.85MHz, (RX3B 914.5MHz, TX3C not available)
- Verified to comply with Radio standard EN 300 220-3
- Verified to comply with EMC standard EN 301 489-3
- North American version conforms to FCC part 15.249
- Data rates up to 64kbps
- Fully screened

Available for operation in the 868-870MHz band in Europe and the 902–928MHz (RX3B only) band in North America, both modules combine full screening with internal filtering to ensure EMC compliance by minimising spurious radiation and susceptibility. The TX3C & RX3B will suit one-to-one and multi-node wireless links in such applications as car and building security, EPOS and inventory tracking, remote industrial process monitoring and data networks. Because of their small size and low power requirements, both modules are ideal for use in portable, battery-powered applications such as hand-held terminals.

Transmitter – TX3C

- Crystal-locked PLL, FM modulated at up to 64 kb/s
- Operation from 2.2V to 16V @ 7.5mA
- Built-in regulator for improved stability and supply noise rejection
- 1mW nominal RF output
- Enable facility

Receiver – RX3B

- Single conversion FM superhet with SAW front end filter
- Operation from 2.7V to 16V @ 11mA
- Built-in regulator for improved stability and supply noise rejection
- -100dBm sensitivity @ 1ppm BER, 64kb/s version
- -107dBm sensitivity @ 1ppm BER, 10kb/s version
- AFC (automatic frequency control)
- RSSI output with 60dB range
- Enable facility
- Extremely low LO leakage, -120dBm typical

Functional description

The TX3C transmitter module uses a frequency modulated crystal-locked PLL and operates between 2.2V and 16V at a current of 7.5mA nominal. At 3V supply it delivers nominally 0dBm (1mW) RF output. The SIL style TX3C measures 32 x 12 x 3.8 mm, excluding pins.

The RX3B module is a single conversion FM superhet receiver capable of handling data rates of up to 64kbps. It will operate from a supply of 2.7V to 16V and draws 11mA when receiving. The RX3B features a fast power-up time for effective duty cycle power saving and a signal strength (RSSI) output with 60dB of range. Full screening and a SAW front-end filter give good immunity to interference. The SIL style RX3B measures 48 x 17.5 x 4.5 mm, excluding pins.

TX3C transmitter

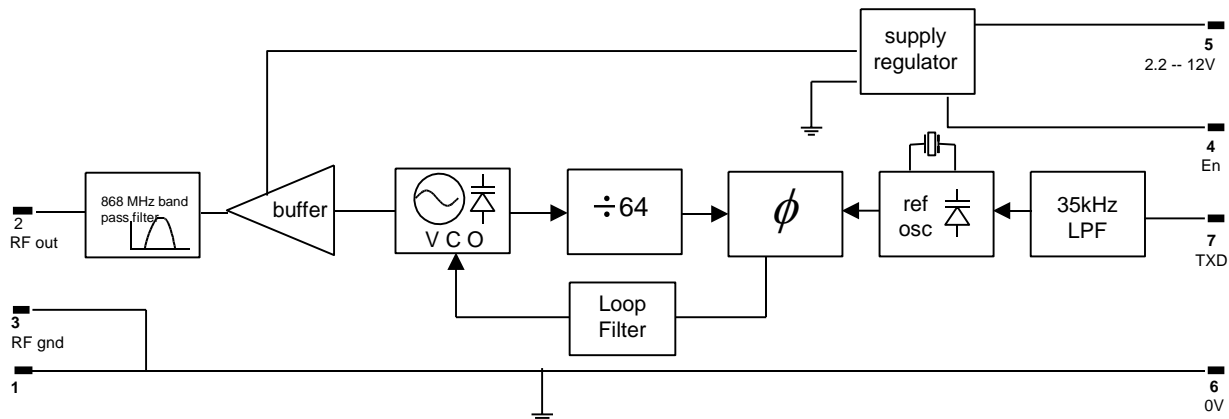

Fig 1 :TX3C block diagram

Pin description

RF GND (pins 1&3)

RF ground, internally connected to the module screen and pin 6 (0V). These pins should be directly connected to the RF return path - e.g. coax braid, main PCB ground plane etc.

RF OUT (pin 2)

50Ω RF output to the antenna. Internally DC-isolated. See antenna section of apps notes for details of suitable antennas.

En (pin 4)

Tx enable. <0.15V shuts down module (current <1μA). >1.7V enables the transmitter. Impedance ~1MΩ. Observe slew rate requirements (see apps notes).

Vcc (pin 5)

+2.2V to +16V DC supply. Max ripple content 0.1V_{P-P}. Decoupling is not generally required.

0V (pin 6)

DC supply ground. Internally connected to pins 1 & 3 and module screen.

TXD (pin 7)

DC-coupled modulation input. Accepts serial digital data at 0V to 2.5V levels. See applications notes for suggested drive methods. Input is high impedance (>100kΩ).

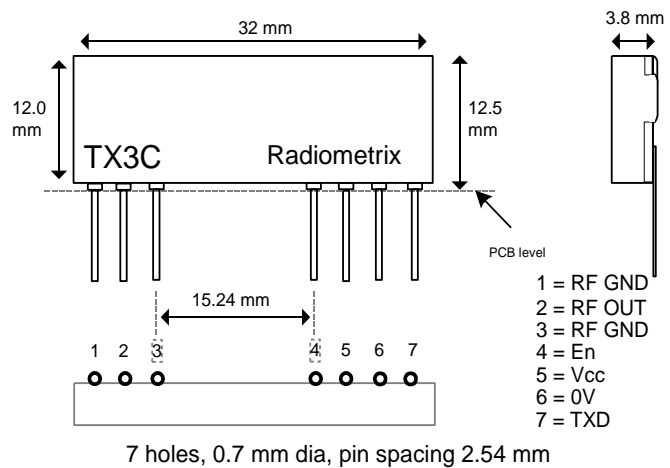

Fig2: TX3ACphysical dimensions

RX3B receiver

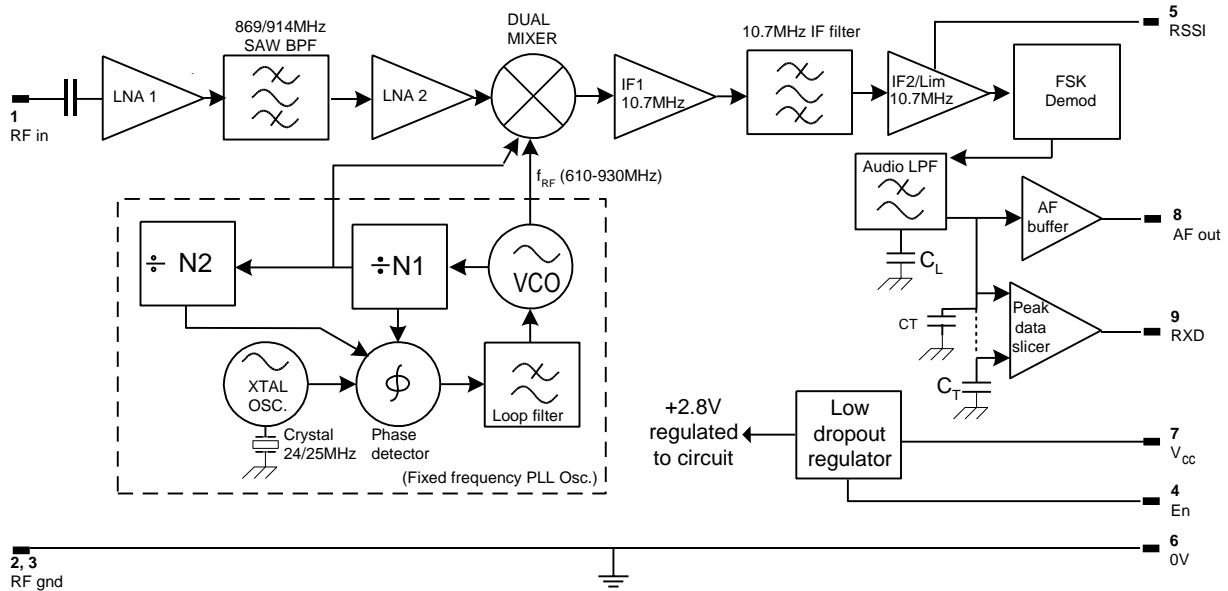

Fig.3: RX3B block diagram

Pin description

RF IN (pin 1)

50Ω RF input from antenna. Internally DC-isolated. See antenna section of applications notes for suggested antennas and feeds.

RF GND (pins 2 & 3)

RF ground, internally connected to the module screen and pin 6 (0V). These pins should be connected to the RF return path - e.g. coax braid, main PCB ground plane etc.

En (pin 4)

Rx enable. <0.15V shuts down module (current <1μA). >1.7V enables the receiver. Impedance ~1MΩ. Observe slew rate requirements (see apps notes).

RSSI (pin 5)

Received signal strength indicator with >60dB range. See applications notes for typical characteristics.

0V (pin 6)

DC supply ground. Internally connected to pins 2 & 3 and module screen.

Vcc (pin 7)

+2.7V to +16V DC supply. Max ripple content 0.1V_{P.P.}. Decoupling is not generally required.

AF out (pin 8)

Buffered and filtered analogue output from the FM demodulator. Standing DC bias 1V approx. External load should be >10kΩ // <100pF.

RXD (pin 9)

Digital output from the internal data slicer. The data is true data, i.e. as fed to the transmitter. Output is 2.8V P/P (not open collector)

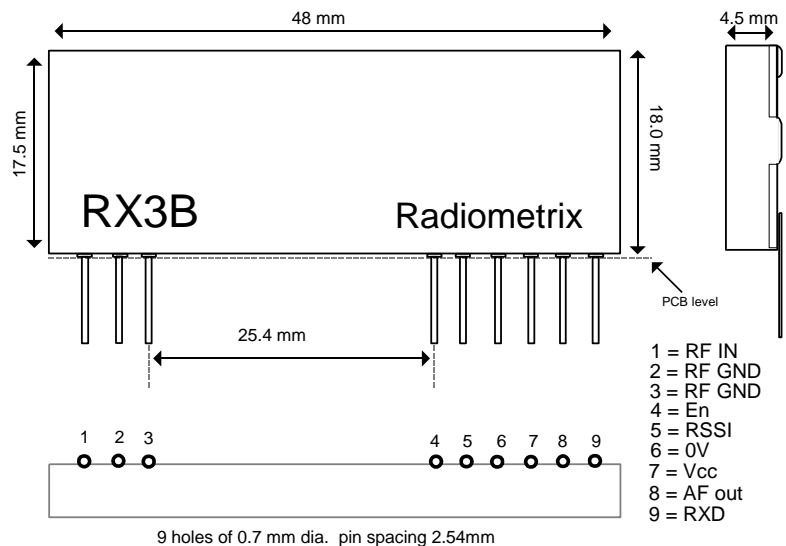

Fig.4: RX3B physical dimensions

Absolute maximum ratings

Exceeding the values given below may cause permanent damage to the module.

Operating temperature	-20°C to +70°C
Storage temperature	-40°C to +100°C

TX3C

Vcc (pin 5)	-0.3V to +16V
TXD (pin 7)	±7V
En (pin 4)	-0.3V to +Vcc V
RF OUT (pin 2)	±50V DC, +10dBm RF

RX3B

Vcc, RXD (pins 7,9)	-0.3V to +16V
En (pins 4)	-0.3V to +Vcc V
RSSI, AF (pins 5, 8)	-0.3V to +3V
RF IN (pin 1)	±50V DC, +10dBm RF

Performance specifications: TX3C transmitter (Vcc = 3.0V / temperature = 20°C unless stated)

	pin	min.	typ.	max.	units	notes
DC supply						
Supply voltage	5	2.2	3.0	16	V	1,6
Supply current	5		7.5	9.5	mA	2
RF						
RF power output @ Vcc = 2.2V	2		-1		dBm	2
RF power output @ Vcc ≥ 2.8V	2		0		dBm	2
Harmonics / spurious emissions	2		-55	-45	dBc	3
Initial frequency accuracy		-25	0	+25	kHz	
FM deviation (peak)			±30		kHz	4
Baseband						
Modulation bandwidth @ -3dB		0		35	kHz	
Modulation distortion (THD)			5	10	%	6
TXD input level (logic low)	7	-0.2	0	+0.2	V	5,6
TXD input level (logic high)	7	+2.3	+2.5	+3	V	5,6
Dynamic timing						
Power-up time (En → full RF)			1.0	1.5	ms	

Notes:

1. RF output is automatically disabled below 2.2V supply voltage.
2. RF output terminated with 50Ω resistive load.
3. Meets or exceeds EN/FCC requirements at all frequencies.
4. With 0V – 2.5V modulation input.
5. To achieve specified FM deviation.
6. See applications information for further details.

Performance specifications: RX3B receiver
(Vcc = 3.0V / temperature = 20°C unless stated)

	pin	min.	typ.	max.	units	notes
DC supply						
Supply voltage	7	2.7	5.0	16	V	
Supply current	7	10	11	16	mA	1
RF/IF						
RF sensitivity @ 10dB (S+N)/N	1, 8		-110		dBm	10kbps
RF sensitivity @ 10dB (S+N)/N	1, 8		-109		dBm	64kbps
RF sensitivity @ 1ppm BER	1, 9		-107		dBm	10kbps
RF sensitivity @ 1ppm BER	1, 9		-102		dBm	64kbps
Max operational RF input	1		-10		dBm	
RSSI threshold	1,5		-120		dBm	
RSSI range	1,5		60		dB	
IF bandwidth			180		kHz	
Image rejection	1	50	60		dB	
IF rejection (10.7MHz)	1	80	85		dB	
LO leakage, conducted	1		-120	-110	dBm	
Baseband						
Baseband bandwidth @ -3dB	8	0		7.8	kHz	10kbps
Baseband bandwidth @ -3dB	8	0		50	kHz	64kbps
AF level	8	200	300	400	mV _{P-P}	2
DC offset on AF out	8		0.9	1.7	V	3
Distortion on recovered AF	8		3	10	%	
Ultimate (S+N)/N	8		30		dB	
Load capacitance, AFout / RXD	8,9			100	pF	
RXD output	9		2.8		V	5
Dynamic timing						
<i>Power up with signal present</i>						
Power up to valid RSSI	4,5		0.7		ms	
Power up to stable data	4,9		1.6	2	ms	2, 10kbps
Power up to stable data	4,9		1.7	2	ms	2, 64kbps
<i>Signal applied with supply on</i>						
RSSI response time (rise/fall)	1, 5		100		µs	
Signal to stable data	1, 9		1.5	2	ms	2, 10kbps
Signal to stable data	1,9		0.1	0.2	ms	2, 64kbps
Time between data transitions	9	0.1		15		4, 10kbps
Time between data transitions	9	15.6		1500	µs	4, 64kbps
Mark : space ratio	9	48	50	52	%	

- Notes:**
1. Current increases at higher RF input levels (-20dBm and above).
 2. For received signal with ±30kHz FM deviation.
 3. DC level after stabilisation over ±100kHz offset.
 4. For 50:50 mark to space ratio (i.e. square wave).
 5. RXD output is fixed at 2.8v

Module test circuits

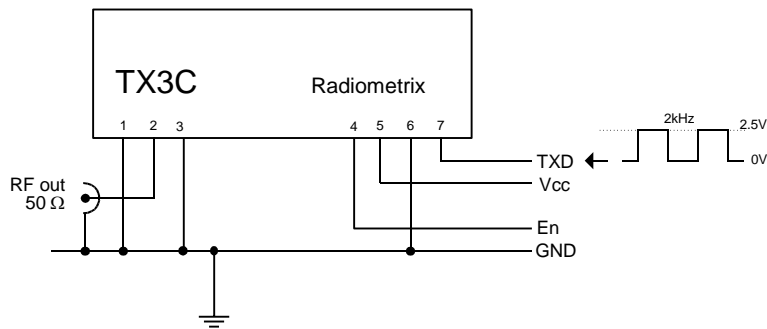

Fig.5: TX3C test circuit

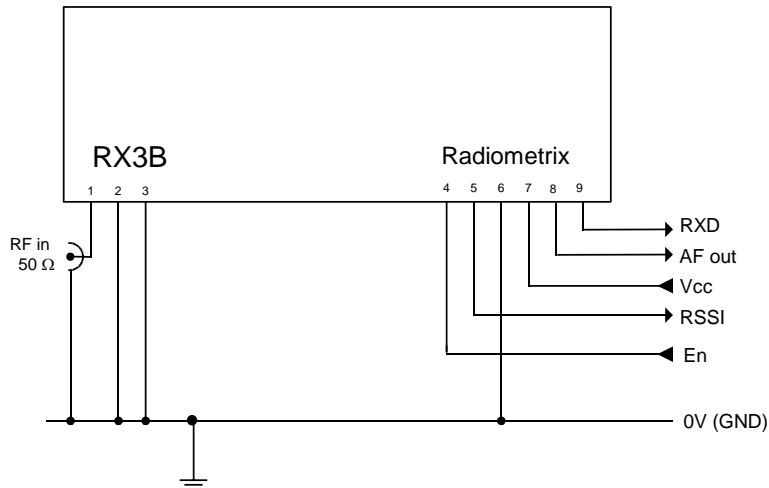

Fig.6: RX3B test circuit

Applications information

Power supply requirements

Both modules incorporate a built-in regulator which delivers a constant 2.8V to the module circuitry when the external supply voltage is 2.85V or greater, with 40dB or more of supply ripple rejection. This ensures constant performance up to the maximum permitted supply rail and removes the need for external supply decoupling except in cases where the supply rail is extremely poor (ripple/noise content $>0.1V_{p-p}$).

Note, however, that for supply voltages lower than 2.85V the regulator is effectively inoperative and supply ripple rejection is considerably reduced. Under these conditions the ripple/noise on the supply rail should be below $10mV_{p-p}$ to avoid problems. If the quality of the supply is in doubt, it is recommended that a $10\mu F$ low-ESR tantalum or similar capacitor be added between the module supply pin (Vcc) and ground, together with a 10Ω series feed resistor between the Vcc pin and the supply rail.

The Enable pin allows the module to be turned on or off under logic control with a constant DC supply to the Vcc pin. The module current in power-down mode is less than $1\mu A$.

NOTE: If this facility is used, the logic control signal must have a slew rate of $40mV/\mu s$ or more. Slew rates less than this value may cause erratic operation of the on-board regulator and therefore the module itself.

The TX3C incorporates a low voltage shutoff circuit which prevents any possibility of erratic operation by disabling the RF output if the supply voltage drops below 2.2V ($\pm 5\%$). This feature is self-resetting, i.e. restoring the supply to greater than 2.2V will immediately restore full RF output from the module.

TX3C modulation requirements

The module will produce the specified FM deviation with a TXD input to pin 7 of 2.5V amplitude, i.e. 0V “low”, 2.5V “high”. Reducing the amplitude of the data input from this value (usually as a result of reducing the supply voltage) reduces the transmitted FM deviation to typically $\pm 25\text{kHz}$ at the lower extreme of 2.2V. The receiver will cope with this quite happily and no significant degradation of link performance should be observed as a result.

Where standard 2-level digital data is employed with a logic “low” level of $0\text{V} \pm 0.2\text{V}$, the logic “high” level applied to TXD may be any value between +2.5V and +3V for correct operation. However, if using multi-level or analogue signalling the maximum positive excursion of the modulation applied to TXD must not exceed +2.5V or waveform distortion will result. If the input waveform exceeds this level a resistive potential divider should be used at the TXD input to reduce the waveform amplitude accordingly. This input is high impedance ($>100\text{k}\Omega$) and can usually be ignored when calculating required resistor values.

Data formats and range extension

The TX3C data input is normally driven directly by logic levels but will also accept analogue drive (e.g. 2-tone signalling). In this case it is recommended that TXD (pin 7) be DC-biased to 1.25V with the modulation ac-coupled and limited to a maximum of $2.5\text{V}_{\text{p-p}}$ to minimise distortion over the link. The varactor modulator in the TX3C introduces some 2nd harmonic distortion which may be reduced if necessary by predistortion of the analogue waveform. At the other end of the link the RX3C AF output is used to drive an external decoder directly.

Both the AF output on pin 8 and the RXD output on pin 9 of the RX3B are “true” sense, i.e. as originally fed to the transmitter.

Although the modulation bandwidth of the TX3C extends down to DC, as does the AF output of the RX3B, it is not advisable to use data containing a DC component. This is because frequency errors and drifts between the transmitter and receiver occur in normal operation, resulting in DC offset errors on the RX3A audio output.

The RX3B incorporates a low pass filter which works in conjunction with similar filtering in the TX3C to obtain an overall system bandwidth of 32kHz. This is suitable for transmission of data at raw bit rates up to 10kbps and 64kbps, depending on the receiver version. To keep settling times within reasonable limits for the data speed in use, the Peak data slicer in the RX3C is subject to a maximum time limit between data transitions (see page 5). This limitation must be taken into account when choosing a code format. It is strongly recommended that a reasonably balanced code containing no long 1s or 0s (such as Manchester or similar) is employed.

In applications such as longer range fixed links where data speed is not of primary importance, a significant increase in range can be obtained by using the slowest possible data rate together with filtering to reduce the receiver bandwidth to the minimum necessary. In these circumstances, because of the limitations of the internal data slicer it is better to use the RX3C audio output to drive an external filter and data slicer.

RX3C Received Signal Strength Indicator (RSSI)

The RX3C receiver incorporates a wide range RSSI which measures the strength of an incoming signal over a range of 60dB or more. This allows assessment of link quality and available margin and is useful when performing range tests.

The output on pin 5 of the module has a standing DC bias of typically 0.4V with no signal, rising to 1.55V at maximum indication. The RSSI output source impedance is high (~50k Ω) and external loading should therefore be kept to a minimum.

Typical RSSI characteristic is as shown below:

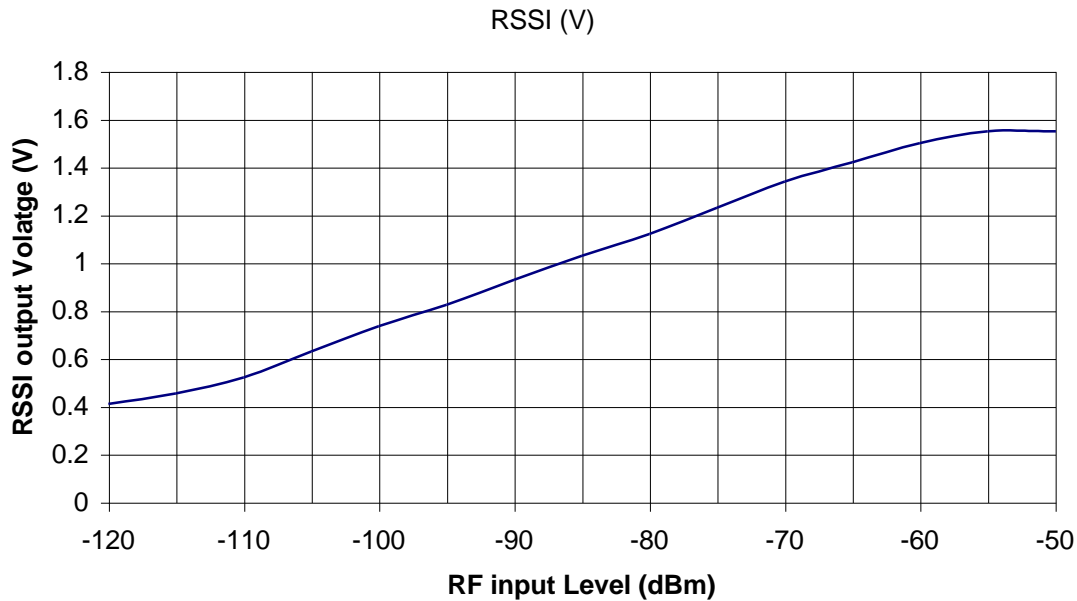

Fig.7: RX3C RSSI response curve

To ensure a reasonably fast response the RSSI has limited internal decoupling of 1nF to ground. This may result in a small amount of ripple on the DC output at pin 5 of the module. If this is a problem further decoupling may be added, in the form of a capacitor from pin 5 to ground, at the expense of response speed. For example, adding 10nF here will increase RSSI response time from 100 μ s to around 1ms. The value of this capacitor may be increased without limit.

Expected range

Predicting the range obtainable in any given situation is notoriously difficult since there are many factors involved. The main ones to consider are as follows:

- Type and location of antennas in use (see below)
- Type of terrain and degree of obstruction of the link path
- Sources of interference affecting the receiver
- “Dead” spots caused by signal reflections from nearby conductive objects
- Data rate and degree of filtering employed (see page 7)

Assuming the maximum 64kbps data rate and unobstructed $\frac{1}{4}$ -wave whip antennas on both transmitter and receiver, the following ranges may be used ***as a rough guide only***:

- | | | |
|---|---|-----------------|
| 1) Cluttered/obstructed environment, e.g. inside a building | : | 25-75m |
| 2) Open, relatively unobstructed environment | : | 100-300m |

It must be stressed that range obtained in practice may lie outside these figures. ***Range tests should always be performed before assuming that a particular range can be achieved in any given application.***

Antenna considerations and options

The choice and positioning of transmitter and receiver antennas is of the utmost importance and is the single most significant factor in determining system range. The following notes apply particularly to integral antennas and are intended to assist the user in choosing the most effective arrangement for a given application.

Nearby conducting objects such as a PCB or battery can cause detuning or screening of the antenna which severely reduces efficiency. Ideally the antenna should stick out from the top of the product and be entirely in the clear, however this is often not desirable for practical/ergonomic reasons and a compromise may need to be reached. If an internal antenna must be used try to keep it away from other metal components and pay particular attention to the “hot” end (i.e. the far end), as this is generally the most susceptible to detuning. The space around the antenna is as important as the antenna itself.

Microprocessors and microcontrollers tend to radiate significant amounts of radio frequency hash, which can cause desensitisation of the receiver if its antenna is in close proximity. 900MHz region is generally less prone to this effect than lower frequencies, but problems can still arise. Things become worse as logic speeds increase, because fast logic edges are capable of generating harmonics across the UHF range which are then radiated effectively by the PCB tracking. In extreme cases system range can be reduced by a factor of 3 or more. To minimise any adverse effects, situate the antenna and module as far as possible from any such circuitry and keep PCB track lengths to the minimum possible. A ground plane can be highly effective in cutting radiated interference and its use is strongly recommended.

A simple test for interference is to monitor the receiver RSSI output voltage, which should be the same regardless of whether the microcontroller or other logic circuitry is running or in reset.

Depending on the application and bearing in mind applicable legal requirements (see p.11), a variety of antenna types may be used with the TX3C and RX3B.

Integral antennas generally do not perform as well as externally mounted types, however they result in physically compact equipment and are the preferred choice for portable applications. The following can be recommended:

Whip ($\frac{1}{4}$ -wave). This consists simply of a piece of wire or rod connected to the module at one end. The lengths given below are from module pin to antenna tip including any interconnecting wire or tracking. This antenna is quite simple and performs well, especially if used in conjunction with a ground plane. This will often be provided by the PCB on which the module is mounted, or by a metal case.

Base-loaded whip. This is a shortened whip, tuned by means of a coil inserted at the base. This coil may be air-wound for maximum efficiency, or a small SMT inductor can be used if space is at a premium. The value must be carefully chosen to tune the particular length of whip in use, making this antenna more difficult to set up than a $\frac{1}{4}$ -wave whip.

Helical. This is a compact but slightly less effective antenna formed from a coil of wire. It is very efficient for its size, but has high Q and tends to suffer badly from detuning caused by proximity to nearby conductive objects. It needs to be carefully trimmed for best performance in a given situation and the required dimensional tolerances can be difficult to achieve repeatably, nevertheless it can provide a very compact solution.

Loop. A loop of PCB track, tuned and matched with 2 capacitors. Loops are relatively inefficient but have good immunity to proximity detuning, so may be preferred in shorter range applications where very high component packing density is necessary.

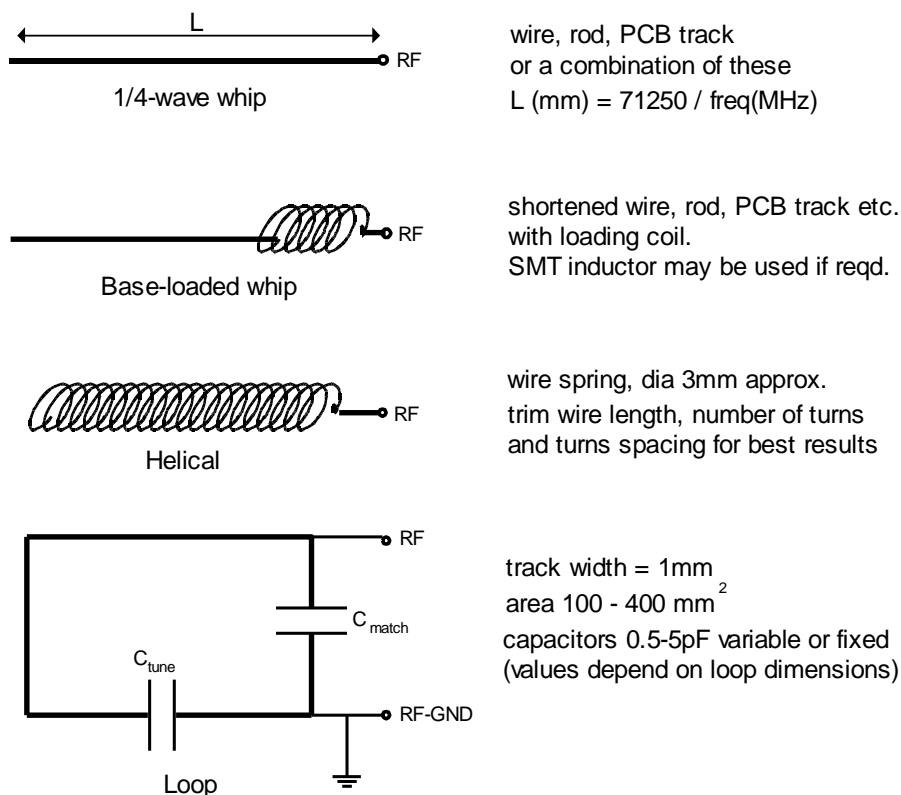

Fig.8: Integral antenna configurations

Integral antenna summary:

	whip	loaded whip	helical	loop
Ultimate performance	***	**	**	*
Ease of design set-up	***	**	*	*
Size	*	***	***	**
Immunity to proximity effects	**	*	*	***

External antennas have several advantages if portability is not an issue. They can be optimised for individual circumstances and may be mounted in relatively good RF locations away from sources of interference, being connected to the equipment by coax feeder. Apart from the usual whips, helicals etc, low-profile types such as microstrip patches can be very effective at these frequencies. Suitable antennas are available from many different sources and are generally supplied pre-tuned to the required frequency.

Type Approval requirements: Europe

The modules are verified to comply with European harmonised standard EN 300 220-3 and EMC standard EN 301 489-3 by United Kingdom Accreditation Service (UKAS) accredited Test Laboratory. The modules are CE Certified by independent Notified Body. The following provisos apply:

- 1) The modules must not be modified or used outside their specification limits.
- 2) The modules may only be used to transfer digital or digitised data. Analogue speech and/or music are not permitted.
- 3) The TX3B must not be used with gain antennas such as multi-element Yagi arrays, since this may result in allowed ERP or spurious emission levels being exceeded.
- 4) Final product incorporating the TX3A/RX3A should itself meet the essential requirement of the R&TTE Directive and a CE marking should be affixed on the final product.

Type Approval requirements: USA

Radiometrix RX3B modules are sold as component devices which require external components and connections to function. They are designed to comply with FCC Part 15.249 regulations, however they are not approved by the FCC. The purchaser understands that FCC approval will be required prior to the sale or operation of any device containing these modules.

- 1) Antennas must be either permanently attached (i.e. non-removable) or must use a connector which is unique or not commonly available to the public.
- 2) The user must ensure that the TX3C/antenna combination does not radiate more than the maximum permitted level of 50mV/m at 3m distance (FCC Part 15.249).
- 3) The appropriate FCC identifying mark and/or part 15 compliance statement must be clearly visible on the outside of the equipment containing the module(s).

Module mounting considerations

The modules may be mounted vertically or bent horizontal to the motherboard. Good RF layout practice should be observed – in particular, any ground return required by the antenna or feed should be connected directly to the RF GND pins at the antenna end of the module, and not to the OV pin which is intended as a DC ground only. All connecting tracks should be kept as short as possible to avoid any problems with stray RF pickup.

If the connection between module and antenna does not form part of the antenna itself, it should be made using 50Ω microstrip line or coax or a combination of both. It is desirable (but not essential) to fill all unused PCB area around the module with ground plane.

The module may be potted, provided that precautions are taken to ensure that no compound can enter the screening can during the potting process.

Warning: *DO NOT wash the module. It is not hermetically sealed.*

Variants and ordering information

The TX3C transmitter and RX3B receiver modules are manufactured in the following variants as standard:

*For European applications in the 868-870MHz band:
Frequency = 869.85MHz*

TX3C-869.85-64	Transmitter
RX3B-869.85-64	Receiver, 64kbps
RX3B-869.85-10	Receiver, 10kbps

*For USA applications in the 902-928MHz band:
Frequency = 914.5MHz*

RX3B-914-64	Receiver, 64kbps
RX3B-914-10	Receiver, 10kbps

Other variants can be supplied to customer requirements, at different frequencies and/or optimised for specific data speeds and formats. Please consult the Sales Department for further information.

Radiometrix Ltd

**Hartcran House
231 Kenton Lane
Harrow, Middlesex
HA3 8RP
ENGLAND**

**Tel: +44 (0) 20 8909 9595
Fax: +44 (0) 20 8909 2233
sales@radiometrix.com
www.radiometrix.com**

Copyright notice

This product data sheet is the original work and copyrighted property of Radiometrix Ltd. Reproduction in whole or in part must give clear acknowledgement to the copyright owner.

Limitation of liability

The information furnished by Radiometrix Ltd is believed to be accurate and reliable. Radiometrix Ltd reserves the right to make changes or improvements in the design, specification or manufacture of its subassembly products without notice. Radiometrix Ltd does not assume any liability arising from the application or use of any product or circuit described herein, nor for any infringements of patents or other rights of third parties which may result from the use of its products. This data sheet neither states nor implies warranty of any kind, including fitness for any particular application. These radio devices may be subject to radio interference and may not function as intended if interference is present. We do NOT recommend their use for life critical applications.

The Intrastat commodity code for all our modules is: 8542 6000

R&TTE Directive

After 7 April 2001 the manufacturer can only place finished product on the market under the provisions of the R&TTE Directive. Equipment within the scope of the R&TTE Directive may demonstrate compliance to the essential requirements specified in Article 3 of the Directive, as appropriate to the particular equipment.

Further details are available on The Office of Communications (Ofcom) web site:

http://www.ofcom.org.uk/radiocomms/ifi/licensing/licensing_policy_manual/

*Information Requests
Ofcom
Riverside House
2a Southwark Bridge Road
London SE1 9HA
Tel: +44 (0)845 456 3000 or 020 7981 3040
Fax: +44 (0)20 7783 4033
information.requests@ofcom.org.uk*

*European Radiocommunications Office (ERO)
Peblingehus
Nansensgade 19
DK 1366 Copenhagen
Tel. +45 33896300
Fax +45 33896330
ero@ero.dk
www.ero.dk*

Radiometrix Ltd

Worldwide Distributors

Radiometrix Ltd

Hartcran House
231 Kenton Lane
Harrow
Middlesex
HA3 8RP
ENGLAND
Tel: +44 (0) 20 8909 9595
Fax: +44 (0) 20 8909 2233
sales@radiometrix.com
www.radiometrix.com

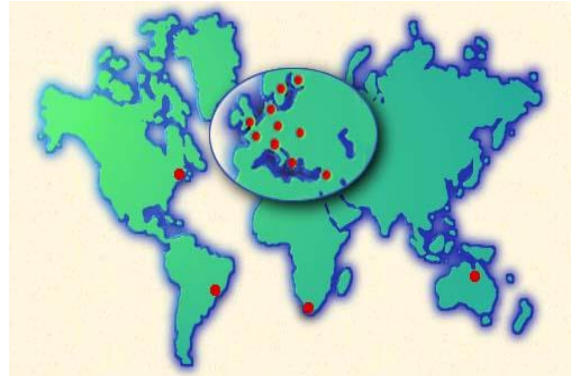

RF Modules Australia

P.O. Box 1957, Launceston,
TAS 7250
AUSTRALIA (including South Pacific)
Tel: +61 3 6331 6789, Fax +61 3 6331 1243
sales@rfmodules.com.au

RS do Brasil Ltda.

Av. Brigadeiro Faria Lima 2413 (6° andar)
01451-001 São Paulo - SP
BRAZIL
Tel: +55 11 3819 0429, Fax: +55 11 3097 0009 or 11 3815 1162
vendas@rsdobrasil.com.br

C-88 AS

Savsvinget 7,
DK-2970 Hørsholm
DENMARK
Tel: +45 7010 4888, Mobile: +45 2320 8589,
Fax: +45 7010 4889
C88@c88.dk

Lextronic

36/40 Rue du Gal de Gaulle,
94510 La Queue en Brie
FRANCE
Tél: +33 (0)1 4576 8388, Fax: +33 (0)1 4576 8141
infos@lextronic.fr

Haril

2A Tsokopoulou Street, 152 37 Filothei, Athens
GREECE
Tel : +302 10 6810338, Fax: +30 10 6853359
harico@otenet.gr

Microrobot Co. Ltd.

Bowoo Bldg., 40-26, Cheongdam-dong, Kangnam-gu,
Seoul, 135-102
KOREA
Tel: +82 2 540 1710, Fax: +82 2 540 1720
maroboss@microrobot.com

HY-LINE AG

Forbüelstrasse 16, CH-8245 Feuerthalen
SWITZERLAND
Tel: +41-52 659 63 03, Fax: +41-52 659 63 93
power@hy-line.ch

IDVISION B.V.B.A

Augustijnenstraat 44
B-8900 Ieper
BELGIUM (including NETHERLANDS, LUXEMBOURG)
Tel.: +32 57 216141, Fax: +32 57 216434
info@idvision.net

Advanced Radio Telemetry

Francouzská 82
602 00 Brno
Tel.: +420 (5)4521 1403, Fax: +420 (5)4521 0506
CZECH REPUBLIC
art@artbrno.cz

TQ Electronic Oy

Laurinkatu 40
08100 Lohja
FINLAND
Tel: +358 19 326451, Fax: +358 19 326452,
Mobile: +358 400 670 697
raimo@tqelectronic.fi

HY-LINE Communication Products GmbH

Inselkammerstraße 10,
D-82008 Unterhaching
GERMANY (including AUSTRIA)
Tel: +49 89 61450319, Fax: +49 89 6140960
communication@hy-line.de

Avnet Components Israel Ltd

P.O.BOX 48, Tel Mond, 40600
ISRAEL
Tel : +972 9 7966999, Fax: +972 3 7601115
shuki.herzlinger@avnet.com

RF Design Ltd

Suite 19, 220 Ottery Road, Wynberg
Cape Town 7945
SOUTH AFRICA
Tel: +27-21-762-5365, FAX: +27-21-797-1983
sales@rfdesign.co.za

Lemos International Co. Inc.

1275 Post Rd, Suite A-12, Fairfield, Ct. 06824
UNITED STATES OF AMERICA
Tel: +1 203 254 1531, Fax: +1 203 254 7442
sales@lemosint.com